

Guidance for Sweep Auger Operations in Grain Bins



November 2013

National Grain and Feed Association



Copyright © 2013

By the National Grain and Feed
Association
1250 I St., N.W., Suite 1003
Washington, D.C., 20005-3922
E-Mail: ngfa@ngfa.org
Web Site: www.ngfa.org

All Rights Reserved. No portion of this publication may be reproduced or transmitted in any form or by any means, electronic or mechanical, without prior permission in writing from the publisher.

Certain text and pictures in this guidance document are reprinted by permission from the Grain and Feed Association of Illinois *Newsletter*, Vol. 25, No. 7, October 2, 2013.

Disclaimer: The NGFA prepared this guidance document to assist grain handling facilities with sweep auger operations. The National Grain and Feed Association makes no warranties, expressed or implied, concerning the accuracy, application or use of the information contained in this publication. Further, nothing contained herein is intended as legal advice. Competent legal counsel should be consulted on legal issues.

SWEEP AUGER POLICY GUIDANCE DOCUMENT

FOR GRAIN ELEVATORS

This guide provides basic concepts to assist grain handling facilities in developing and implementing a sweep auger operations safety policy. As such, it should be viewed as a foundation upon which individual companies can build their own tailored plans specific to their facility, operations, personnel, and other conditions. The example policy attached provides a template that may be used for developing a site-specific sweep auger operations safety policy.

This document is based on Federal OSHA standards. More than half the states in the U.S. administer their own job safety and health programs (State Plans). These State Plans operate with the approval of Federal OSHA so long as the programs are “at least as effective” as the Federal OSHA program. However, these states may have standards more stringent than Federal OSHA. As a result, employers operating in a State Plan jurisdiction must comply with the regulations, standards and policies of that State Plan.

BACKGROUND

Over the past several years there has been uncertainty within the grain handling industry on what type of sweep-auger equipment can be used and the types of procedures the Occupational Safety and Health Administration (OSHA) may find acceptable.

In 2009, OSHA issued a [letter of interpretation](#) that essentially created a new policy for operating sweep augers inside grain bins. In the letter, OSHA stated an employee cannot work inside a bin with an energized sweep auger, unless the auger was “completely guarded.” The Agency did not offer any acceptable alternative procedures for removing grain from a bin if a partially guarded auger cannot be used, nor did OSHA define what is meant by completely guarded or unguarded. Prior to the letter, it was common practice in the industry to “guard”, or cover the top and back of the auger while in operation. Following the letter, OSHA stated that the entire auger, including the front, needed to be covered. However, a sweep-auger cannot properly function if it is completely guarded.

As a result, OSHA issued numerous citations to grain-handling facilities for allowing employees to work around “unguarded” sweep augers. This caused confusion within the industry since many were unsure of what type of sweep-auger equipment could be used and the types of procedures OSHA may find acceptable.

SETTLEMENT AND MEMORANDUM

Thus, several NGFA members legally challenged OSHA citations based on the 2009 letter of interpretation. Following a [settlement agreement in early 2013](#), OSHA released a [sweep auger policy memo in May 2103](#).

Overall, the memo is a very positive step in answering many of the industry's questions regarding the agency's sweep auger enforcement policies that have fluctuated over the past several years.

OSHA also referenced the memo in a formal response to a letter that the NGFA sent to the Agency in 2010 asking for clarification on the 2009 letter of interpretation. In the correspondence, OSHA states that the May 2013 sweep auger policy memo, "clarifies the agency's position on this matter and addresses NGFA's concerns associated with the sweep augers."

OSHA's sweep auger policy memo states that employees are allowed to be physically inside a bin with an energized sweep auger provided:

- the only unguarded portion of the auger is in front;
- sub-floor augers are guarded by secure grates or other guards;
- there is an engineering control (such as a standard guardrail attached to the auger, a portable guard rail trailing seven feet behind the auger, or a dead-man switch on an operating control inside an enclosure or attached to a handle that keeps the employee seven feet back from the auger); **and** the facility's bin entry permit procedures are followed.

In total, there are 10 criteria outlined in the memo (which are further described in this document) regarding employee entry into bins with mobilized sweep augers (including those mentioned above). Also detailed is compliance with OSHA's existing bin-entry procedures specified in the grain handling safety standard (e.g., obtaining permits, providing proper entry equipment, stationing trained and equipped observers, etc.). Almost the entire document is based upon the existing requirements under 29 CFR 1910.272 - Grain Handling Standard.

However, the ten items in the memorandum have not been implemented as law through a formal rulemaking process, and represent only good guidance. As such, enforcement by OSHA will likely be determined on a case-by-case basis with no single factor predominating. Therefore, if an employee is injured or killed inside a bin while a sweep auger is operating, OSHA may find an employee was in the "zone of danger." In other words, the OSHA memo can be useful for a company that has implemented and is following good safety procedures when an OSHA inspection occurs, provided that an inspection is not predicated on an accident involving an employee injury.

Further, if the current policy of your company is not to enter grain bins with equipment running then that is the policy to follow. We are not suggesting you change it!

OVERVIEW OF THE TEN POINTS IN THE OSHA ENFORCEMENT

MEMORANDUM

1. Workers may not enter grain bin until after issuance of a bin entry permit, certifying that the precautions contained in 1910.272 (g) have been implemented, unless the employer or employer representative (who would otherwise authorize the permit) is present during the entire operation.

This is taken directly from the grain storage structure entry section of the OSHA Grain Handling Standard - [29 CFR 1910.272 \(g\)](#) (bins, silos and tanks). Each time an employee enters a bin the hazards must be evaluated.

1910.272(g)(1)(i) -The employer shall issue a permit for entering bins, silos, or tanks unless the employer or the employer's representative (who would otherwise authorize the permit) is present during the entire operation. The permit shall certify that the precautions contained in this paragraph (1910.272(g)) have been implemented prior to employees entering bins, silos or tanks. The permit shall be kept on file until completion of the entry operations.

In addition, this point also applies to sweep augers that are used in structures covered under 1910.272(h) (flat storage).

1910.272(h) Entry into flat storage structures. For the purposes of this paragraph (h), the term "grain" means raw and processed grain and grain products in facilities within the scope of paragraph (b)(1) of this section.

Examples of Dangerous Entry Conditions

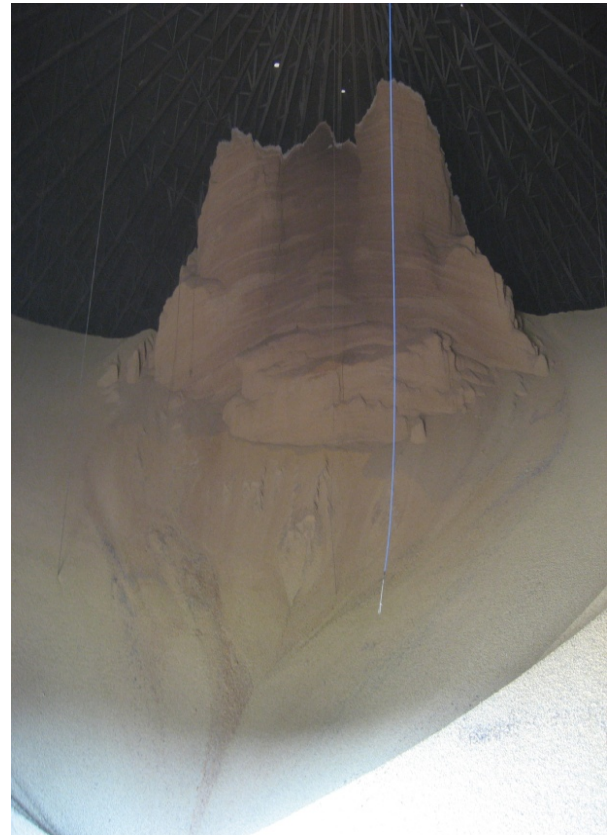

2. Before entering the bin to set up or dig out the sweep auger, the subfloor auger and the grain entry points must be de-energized and locked out. **Once again, this is taken directly from the entry section of the grain handling standard.**

1910.272(g)(1)(ii) - All mechanical, electrical, hydraulic, and pneumatic equipment which presents a danger to employees inside grain storage structures shall be deenergized and shall be disconnected, locked-out and tagged, blocked-off, or otherwise prevented from operating by other equally effective means or methods.

1910.272(h)(2)(i) - Whenever an employee walks or stands on or in stored grain or grain products of a depth which poses an engulfment hazard, all equipment which presents a danger to that employee (such as an auger or other grain transport equipment) shall be deenergized, and shall be disconnected, locked-out and tagged, blocked-off, or otherwise prevented from operating by other equally effective means or methods.



3. Before operating the sweep auger, the grate/guard on the sub-floor auger must be in place and secured.

The memo states that all sump guards must be secured before sweep auger operations. If sump gates are closed (& locked out) and full of grain you do not need the grates. In the event that employees will be scooping into the center or intermediate sump holes, they must be guarded. Please note the sump grates must comply with 29 CFR 1910 Subpart O (which is discussed later in the document).

Examples of Sump Guards

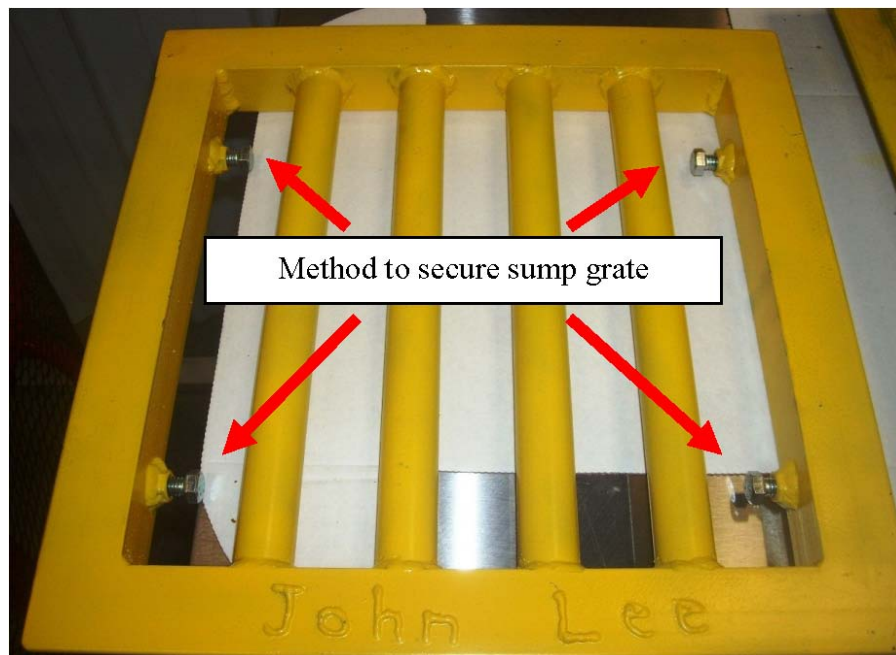
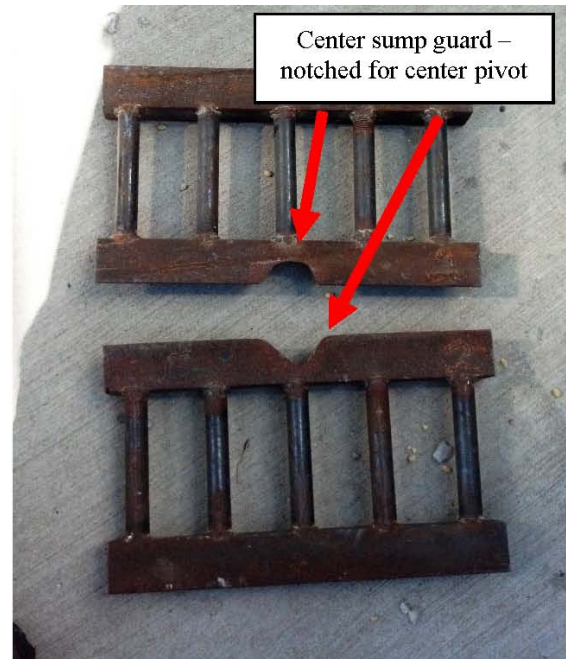
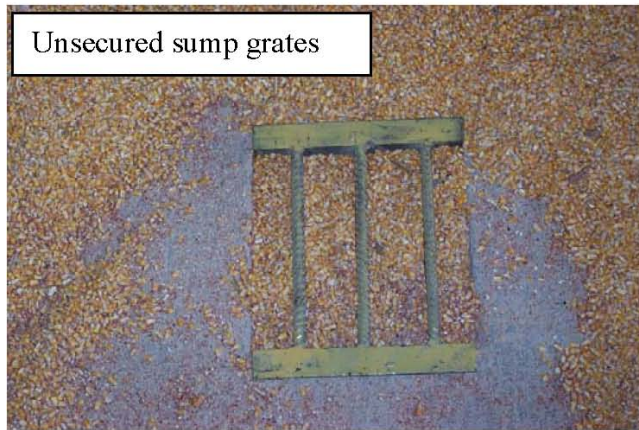

4. Employees operating the sweep auger cannot walk on the grain, if the depth of the grain presents engulfment hazard.

This is taken directly from the grain storage structure entry section of the grain standard. Waist deep is the maximum allowed depth.

1910.272(h)(2)(ii) "Walking down grain" and similar practices where an employee walks on grain to make it flow within or out from a grain storage structure, or where an employee is on moving grain, are prohibited.

5. All sweep augers (including portable sweep augers) must be provided with guards that protect against contact with moving parts at both the top and back areas. The only unguarded portion of the sweep auger should be the front point of operation.

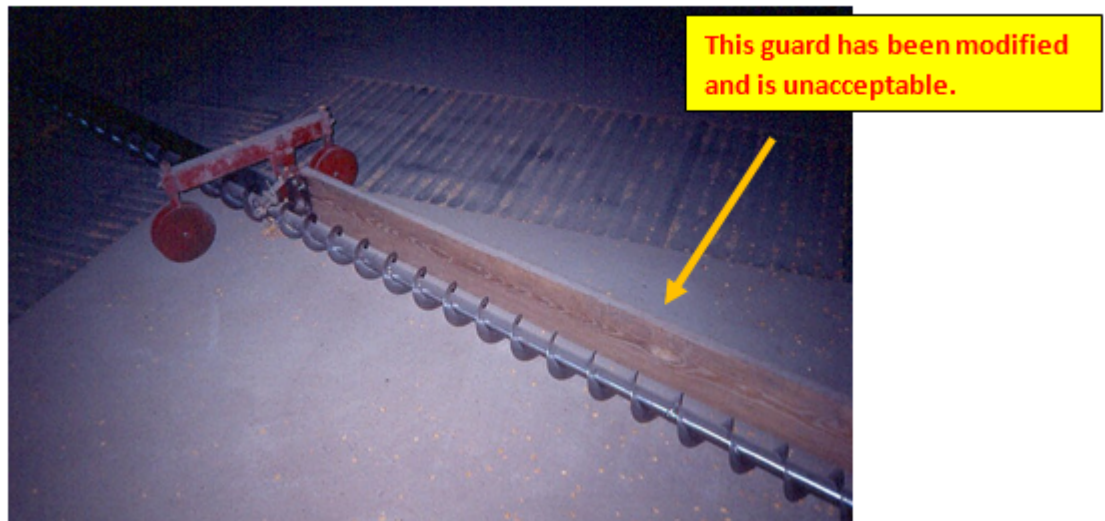

6. A trained and equipped observer, in accordance with 1910.272(g), must always be positioned outside the storage bin monitoring the activities of all workers inside the bin.

This is taken directly from the grain storage structure entry section of the grain handling standard. In addition, the employee acting as observer shall be trained in rescue procedures, including notification methods for obtaining additional assistance, as indicated in 1910.272 (g)(5).

1910.272(g)(3) - An observer, equipped to provide assistance, shall be stationed outside the bin, silo, or tank being entered by an employee. Communications (visual, voice, or signal line) shall be maintained between the observer and employee entering the bin, silo, or tank.

7. If a worker is to enter the bin while the sweep auger is energized, the employer must utilize engineering controls within the grain bin to prevent workers from coming into contact with the energized sweep auger. The use of administrative controls without the use of an engineering control is not a sufficient means of worker protection.

An engineering control is a guard or device to keep employee away from the sweep auger. Administrative control is a policy. For example, company sweep auger operation policy states that all employees will be 7' away from operating sweep auger. There must also be an engineering device to go along with the policy.

Acceptable engineering controls may include:

- a) Sweep auger equipped with an attached safety guard rail which prevents contact with the worker and unguarded portion of the auger in accordance with 1910 Subpart O (Mechanical Power Press).

Subpart O

Distance between Protective Covering and Moving Parts of Equipment	Maximum vertical opening (Horizontal openings are unlimited)
½ to 1 ½ inches	¼ inches
1 ½ to 2 ½ inches	⅜ inches
2 ½ to 3 ½ inches	½ inches
3 ½ to 5 ½ inches	⅝ inches
5 ½ to 6 ½ inches	¾ inches
6 ½ to 7 ½ inches	⅞ inches
7 ½ to 12 ½ inches	1 ¼ inches
12 ½ to 15 ½ inches	1 ½ inches
15 ½ to 17 ½ inches	1 ⅞ inches
17 ½ to 31 ½ inches	2 ⅛ inches
31 ½ inches to less than 7 feet	6 inches
More than 7 feet	Protective Covering not required

This is a chart from the 1910.217 mechanical power press standard. It shows how far away an employee needs to be in relationship to the hazards. The farther the distance away from the hazard the larger the opening can be on the guard. For example, if the subfloor auger is 6 inches below a sump grate or guard, the maximum opening is ¾ inches.

Technically, Subpart O applies only to mechanical power presses. Accordingly, the application of Subpart O measurements for guards on sweep and floor augers is not mandatory or legally binding. However, OSHA has expressly approved the use of the guarding measurements listed in Subpart O with respect to guards for sweep and floor augers. Therefore, Subpart O was included in this memorandum as a resource to which employers may refer about guarding that would be considered by OSHA to be adequate guarding.

- b) Sweep auger equipped with a control mechanism, such as a dead-man switch or other similar device, which will allow for the sweep auger's operation only when the operator is in contact with device. If this method is utilized as a means of worker protection, the worker must be positioned at least seven feet from the auger at all times it is energized; moreover, if worker(s) in addition to the operator of the sweep auger are in the bin, additional engineering controls (such as those described in section 7 of this criteria) must be used to protect those worker(s).

The push bar below has a dead-man switch like a lawn mower. If you let go of the handle, the sweep auger quits.

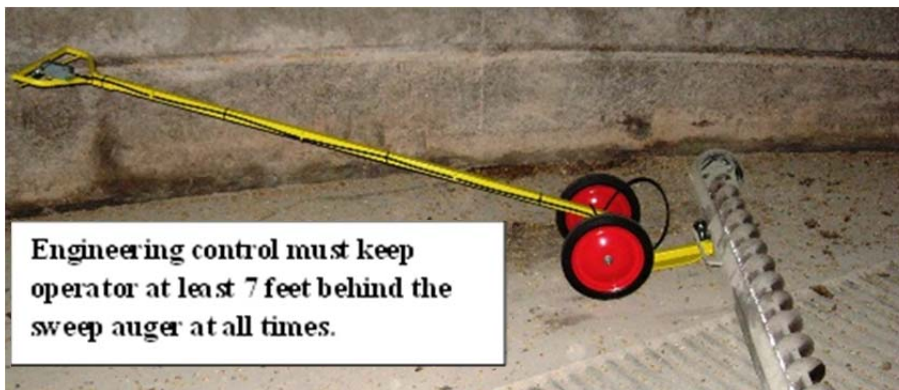

Engineering control must keep operator at least 7 feet behind the sweep auger at all times.

- c) Any workers other than the operator of the sweep auger present in the storage bin while the sweep auger is energized must also be protected in a manner that keeps them out of the zone of danger. For example this may include the installation of guardrails or catwalks that prevent workers from entering the area within the path of the auger. **Portable guardrails are permissible, provided they are placed at least seven feet behind the sweep auger. Note: the use of a warning line, or other easily removable device, other than a portable guardrail, is not considered sufficient engineering controls. See pictures below for examples of acceptable guardrails.**

This is often referred to as a “whiskey barrel”. Note the foot-operated dead-man switch.

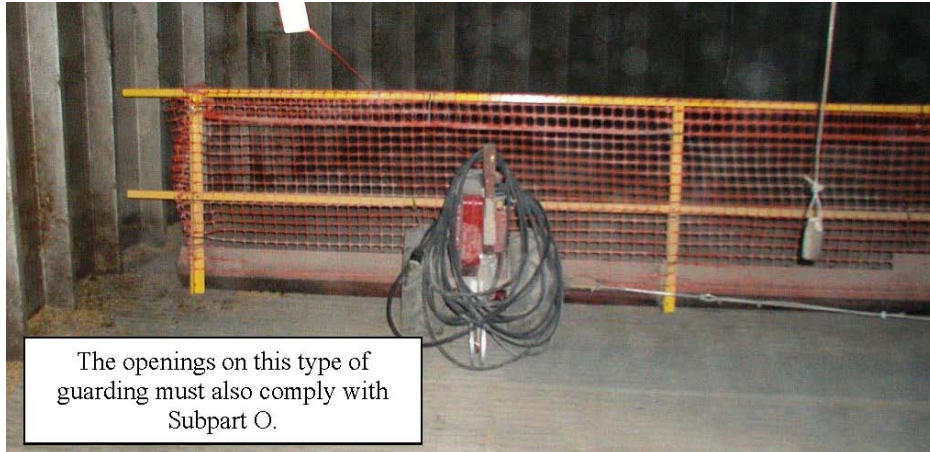

This is often referred to as a “whiskey barrel”. Note the foot-operated dead-man switch.

8. The auger must be provided with a positive speed control mechanism or bin stop device that prevents the uncontrolled rotation of the sweep auger.

A hydraulically driven sweep auger is a positive speed control. The bin stop device and "walker" attachment are for direct drive sweep augers.

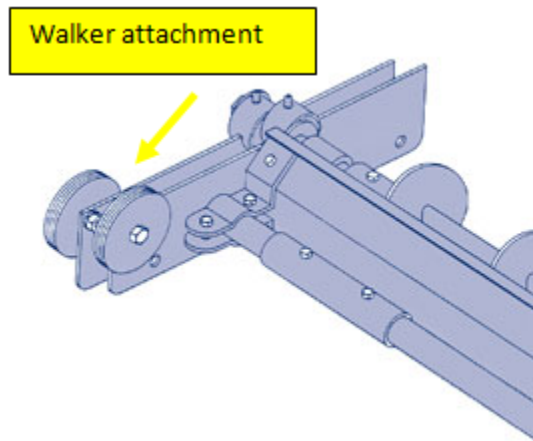
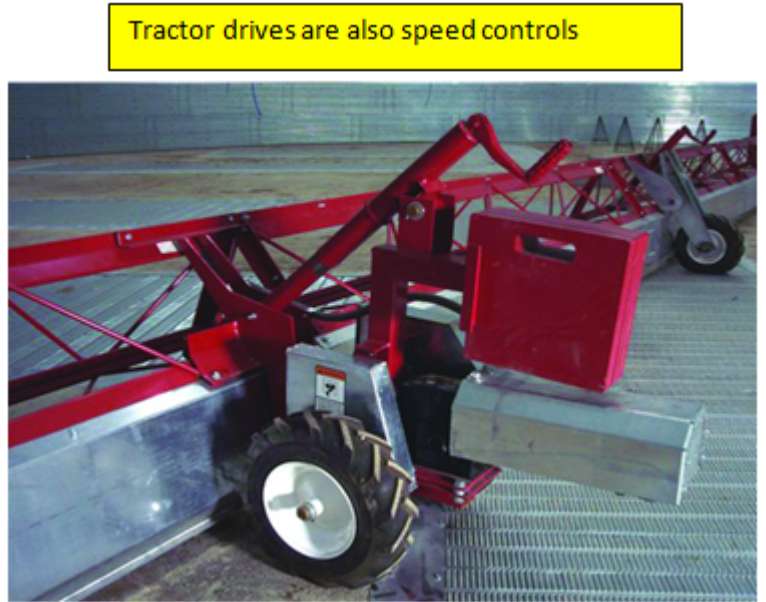

- Workers are prohibited from using their hands, legs, or other similar means to manipulate the sweep auger while it is operating.



Workers may not use their hands, legs, or other similar means to dislodge or otherwise directly manipulate the sweep auger while it is energized.

- If maintenance/adjustments are necessary to the sweep auger, the sweep must be unplugged, with the person making the adjustments maintaining the control of the plug, or locked-out in accordance with lock-out/tag-out procedures.



Sweep Auger Policy – Example

The following example sweep auger policy template is based upon the ten points raised in the OSHA's May 3 Memorandum.

1. PURPOSE AND EXPECTATIONS

- 1.1 This policy covers work by employees inside of grain bins with sweep augers or other conveying equipment.
- 1.2 The requirements in this policy are designed to provide employees working inside grain bins with operating sweep augers with effective means of protection against the hazards presented by sweep augers to comply with applicable OSHA requirements, guidance and case law, and to satisfy the principles set forth in Exhibit A (May 3, 2013 OSHA Memorandum re: Grain Handling Facility Sweep Auger Enforcement Policy).
- 1.3 This policy does not apply if employees are not required to work inside a grain bin.
- 1.4 Any other exception must be expressly approved in advance by the area management representative for the facility, and must comply (Need to keep this in layman's not legal language) with the principles set forth in Exhibit A.

2. DEFINITIONS

Center Sump: The sump located in the center of the grain bin through which the sweep auger moves grain into the discharge equipment.

Dead Man or Safety Switch: A safety switch for equipment that allows operation only while depressed or engaged by the operator.

Deenergized: When energy sources are removed (e.g., an electric motor that is turned off and cannot start because the electric source has been unplugged or the disconnect or breaker is in the "off" position).

Dig Out: Process of removing grain from on top of and around the sweep auger so the auger can operate. This process may also include repositioning the sweep auger. You are simply defining terms. I don't think this statement belongs here. I added it in Step #7.

Discharge Equipment: An auger or conveyor under the bin floor that removes grain from the center sump and intermediate sumps to other equipment outside the bin.

Energized: When an energy source is present allowing equipment to operate.

Intermediate Sump: The sumps located between the grain bin wall and the center sump through which grain enters the discharge equipment.

Kill Switch: A safety device that immediately stops operation of equipment when activated by the operator.

Locked and Tagged Out: The placement of a lock and tag device or other mechanism on an energy isolating device, which physically prevents the unexpected energization, transmission, or release of energy of machines or equipment. See the Company's Lockout Tagout Policy for specific procedures.

Observer: An employee stationed outside a grain bin at all times while employees are inside who remains within reach of a stop or deenergizing device for the sweep auger, and who observes the sweep-cleaning operations. .Again, we are simply defining terms, not going into details of the roles and responsibilities for the Observer. I added these requirements in Step #5.

Operating (also includes Operational and Operated): When an energy source is operating equipment (e.g., a sweep auger is operating when its flighting is turning).

Protective Covering: A material such as snow fence that is attached to the back of standard railing, guards, or other barriers to prevent contact with the moving parts of equipment. Specific requirements need to be explained in detail later on in the policy/procedure and Table O-10 should be an Exhibit. I added this requirement in Section 5 wherever the protective covering was mentioned and also added Table O-10 as Exhibit B.

Standard Railing: Railing that has a vertical height of approximately forty-two (42) inches from the bin floor and an intermediate rail halfway between the top rail and the grain bin floor. The railing shall be capable of withstanding a load of at least two hundred (200) pounds applied to the top rail downwards or towards the sweep auger.

Sweep Auger: An apparatus within a circular bin that moves grain across the bin floor towards the center sump.

Sweep Auger Operator: The employee operating the sweep auger with a remote controlled device, switch, or other electronic control enabling the employee to cause the sweep auger to start and stop.

Sump Guard: A substantial cover, grate, standard railing or barrier that is secured in place over both the Center Sump and all Intermediate Sumps in a bin to guard the opening so employees do not accidentally step into these openings which can result in serious injury. Openings in sump guards must comply with requirements of Table O-10. See Exhibit B.

3. TRAINING

- 3.1 Employees shall receive training in this policy before they are permitted to participate in sweep-cleaning operations.
- 3.2 Training must include a physical demonstration of the sweep auger controls, related safeguarding devices, and related safe work practices.
- 3.3 After completion of training and prior to allowing employees to perform sweep-cleaning operations, employees must demonstrate that they are both knowledgeable and competent with the set up, installation and operation of the sweep auger controls, safeguarding devices and safe work practices by successfully passing a performance evaluation. The performance evaluation will be a written document identifying the criteria evaluated and whether or not the employee passed or failed. In the event of a failure, corrective actions and additional training will be documented for each individual case until the person has successfully passed the performance evaluation. The evaluation will also include the date of the evaluation, signature of the employee and signature of the management person who conducted the performance evaluation. This will be kept on file for documentation purposes.
- 3.4 Refresher training, including the employee performance evaluation, shall be conducted at least annually. Refresher training will also occur when the nature of the work, the workplace, or the implementation of this policy changes, or if the employee demonstrates a lack of understanding of the policy.

4. PREPARATION FOR SWEEP-CLEANING OPERATIONS

Employees shall complete the following steps before beginning any sweep-cleaning operations (these steps are applicable to all alternative sweep auger protection measures):

STEP NO. 1: Empty as much grain as possible from the bin by:

- Gravity through the center and intermediate sumps.
- When grain stops flowing by gravity, turn on all bin aeration fans and continue to remove grain until the flow of grain stops. This technique is often successful in removing substantially more grain from the bin.

STEP NO. 2: Examine equipment related to the sweep-cleaning operation to ensure it is in safe working order.

STEP NO. 3: Follow the Company's Bin Entry Procedure

STEP NO. 4: Ensure the work area has adequate lighting.

STEP NO. 5: Post an observer outside the grain bin at the bin entry point. The Observer:

- Can be the same employee who is required to remain present during the sweep-cleaning operation in lieu of a bin entry permit, as long as the employee is also qualified to be an observer.
- Must be in constant communication with employees inside the bin.
- Must not have any other tasks that interfere with the primary task of monitoring safety during the entry and communicating with employees.
- Cannot leave their post for any reason until all employees have exited the bin.
- Must be trained in rescue procedures including notification procedures to summon help, first aid and CPR.

Note: In larger bins, a second observer (Observer 2) inside the grain bin may be used to assist with communication between the first observer and employees inside the grain bin. Observer 2 shall not conduct other tasks while acting in this capacity. When it is demonstrated to be a feasible option, a video camera inside the grain bin may be used by the observer to maintain communication with employees inside the bin.

STEP NO. 6: Once the bin and all associated equipment has been locked out, the grain does not present an engulfment hazard, the atmosphere has been tested and found to be safe and all other safety precautions have been taken and verified by management, enter the grain bin, and adequately guard all sumps. All sump guards must be secured in place to prevent them from moving or becoming dislodged. If using a sump guard with slotted openings, the openings must comply with the guard opening requirements found in Table O-10 of the OSHA standard. See Exhibit B.

STEP NO. 7: Dig out the sweep auger or otherwise prepare the grain bin for sweep-cleaning operations. During dig out, the sweep auger shall be locked and tagged out, and sump guards shall be secured over all sumps or otherwise guarded. Discharge equipment below the grain bin may be operated during dig out when the sumps are protected by sump guards.

NOTE: Discharge equipment does not include the sweep auger.

STEP NO. 8 Depending on the protective measure being used, (See Section 5) ensure the sweep auger:

- Has a guard installed on the sweep that protects against contact with moving parts at both the top and back areas with the only unguarded portion of the sweep auger being the front point of operation.
- Is properly connected to the safety handle or guard rails, personnel enclosures or other safeguarding measures are properly installed and operational.

STEP NO. 9: Place or activate the sweep auger stop inside the grain bin to prevent the sweep auger from completing a full circle around the bin. The sweep auger stop shall be secured no closer than seven (7) feet from the bin entry point in the direction opposite the sweep auger's direction of travel.

5. SWEEP AUGER PROTECTION MEASURES

5.1. After preparation for sweep-cleaning operations is completed, employees can remain inside the bin during the sweep-cleaning operations as long as one or more of the following additional sweep auger protection measures are used:

- 5.1.1 **Safety Handle:** A handle of at least seven (7) feet in length attached to the back of the sweep auger that is equipped with a dead man switch or safety switch. The switch being used must be designed so that it cannot be easily defeated or bypassed by using tape or zip ties to hold the handle in place so that when the operator releases the handle the sweep auger will continue to operate.

When using the safety handle alternative, only one employee may be inside the grain bin while the sweep auger is operating or energized. More than one employee may be inside the bin when the sweep auger is locked and tagged out.

Limited Exception: Observer 2 may be posted inside the bin with the employee when the sweep auger is operating or energized, but must be protected from the hazards associated with the sweep auger by implementing any of the protective measures identified in 5.1.2 through 5.1.7 of this section.

- 5.1.2 **Attached Standard Railing:** A standard railing mounted to the Sweep Auger. A protective covering shall be attached across the back of the standard railing. The size of the openings of the protective covering shall conform to Table O-10. See Exhibit B.

Before entering the bin to work behind the standard railing, either allow the sweep auger to operate and clear enough of an area to stand and work safely, or dig out and clear such an area before operating the sweep auger.

- 5.1.3 **Portable Standard Railing:** A portable, self-supported standard railing set in place behind the sweep auger. A protective covering shall be attached across the back of the standard railing. The size of the openings of the protective covering shall conform to Table O-10. See Exhibit B.

- 5.1.4 **Operator Enclosure:** A portable enclosure made of standard railing inside of which the Sweep Auger Operator can be stationed with a dead man switch or kill switch while the sweep auger is operating. Alternatively, other electrical controls may be used as long as they shut off the sweep auger when the employee steps outside the enclosure.

When using the operator enclosure alternative, first either allow the sweep auger to operate and clear enough of an area to set up the enclosure on flat ground, or dig out and clear such an area, before entering the enclosure to work behind the sweep auger. Also,

only one employee may be inside the grain bin while the sweep auger is operating or energized. More than one employee may be inside the bin when the sweep auger is locked and tagged out.

Limited Exception: Observer 2 may be posted inside the bin with the employee when the sweep auger is operating or energized, but must be protected from the hazards associated with the sweep auger by implementing any of the protective measures identified in 5.1.2 through 5.1.7 of this section.

- 5.1.5 **Operator Stand:** A stand inside the grain bin mounted to the bin wall or elevated from the grain bin floor above the moving parts of the sweep auger, from where the Sweep Auger Operator can operate and/or observe the sweep-cleaning operations. The Sweep Auger Operator shall have access to a dead man switch or safety switch. Alternatively, other electrical controls may be used as long as they shut off the sweep auger when the employee dismounts the stand.

When using the Operator Stand alternative, only one employee may be inside the grain bin while the sweep auger is operating or energized. More than one employee may be inside the bin when the sweep auger is locked and tagged out.

Limited Exception: Observer 2 may be posted inside the bin with the employee when the sweep auger is operating or energized, but must be protected from the hazards associated with the sweep auger by implementing any of the protective measures identified in 5.1.2 through 5.1.7 of this section.

- 5.1.6 **Light Curtain:** When it is demonstrated to be a feasible option, a light curtain may be installed with a triggering distance of seven (7) feet around the sweep auger, which would shut off the sweep auger whenever an employee moves within the triggering distance.
- 5.1.7 **Future Options:** As additional feasible options are developed, this list of additional sweep auger protection measures may be modified.

6. Safety Requirements for all Sweep-Cleaning Operations

6.1 Employees shall ensure the following safety requirements are implemented during sweep-cleaning operations, regardless of which additional sweep auger protection measures are used:

- 6.1.1 All electrical equipment associated with the sweep auger (including remote operating systems or safety handles), shall be appropriately rated for the hazardous classification of the areas where the equipment will be used. (i.e. Class II for combustible dusts)
- 6.1.2 Employees are prohibited from walking in front of the sweep auger in the area between the sweep auger and the sweep auger stop unless the sweep auger is locked and tagged out and the grain is determined not to present an engulfment hazard. If the sweep auger stop is temporarily disabled in order to allow the sweep auger to begin an additional pass around the grain bin, then employees are prohibited from walking on grain in any area in front of the sweep auger unless the sweep auger is locked and tagged out.
- 6.1.3 Employees are only permitted to work within seven (7) feet behind sweep augers when additional sweep auger protection measures are implemented that will adequately protect an employee from falling into or otherwise contacting the moving parts of the sweep auger, such as the use of attached standard railing (as described in 5.1.2) or portable standard railing (as described in 5.1.3).

- 6.1.4 If the sweep auger or other equipment dislodges a sump guard from a sump, both the sweep auger and the discharge equipment shall be deenergized and locked and tagged out so that the sump guard can be put back in place.
- 6.1.5 If the condition of the grain indicates a hazardous condition, immediately stop the sweep-cleaning operations and exit the grain bin. Sweep-cleaning operations may resume only after the condition is resolved.
- 6.1.6 **Never** use hands, legs or other similar means to manipulate the sweep auger (except for the safety handle as described in Section 5.1.1) while it is operating.
- 6.1.7 **Never** attempt to clean, clear out plugged grain/debris, or conduct maintenance on the sweep auger unless it is locked and tagged out.
- 6.1.8 No employee may make an entry into or attempt to exit a grain bin when the sweep auger is operating or energized and located in the area within seven (7) feet of either side of the bin entry point.
- 6.1.9 The Sweep Auger Operator may be inside the grain bin with a sweep auger that is energized but shut off, so long as the Sweep Auger Operator is the only person who has complete control over the operating controls that cause the sweep auger to operate.

7. DISCIPLINARY ACTION

7.1 Employees are required to follow all of the procedures contained in this written program. Employees are not allowed to deviate from these procedures for any reason. If there is an issue or question regarding this written sweep auger program, the employee must bring these questions or concerns to the attention of top management for proper review. Any employee who knowingly violates the procedures in this program or bypasses/defeats any machine safeguarding devices such as but not limited to safety switches or dead man switches, may be discharged on the first offense.

EXHIBIT A

Criteria for Sweep Auger Alternative Protection Measures to Lock-out/Tag-out

1. Workers may not enter a grain bin until after issuance of a bin entry permit, certifying that the precautions contained in paragraph §1910.272(g) have been implemented, unless the employer or the employer's representative (who would otherwise authorize the permit) is present during the entire operation.
2. Before any worker enters the bin to either set up or dig out the sweep auger, the subfloor auger and the grain entry points must be de-energized and locked-out.
3. Before operation of the sweep auger, the grate/guard on the subfloor auger must be in place and secured.
4. Employees may not walk on the grain where the depth of the grain presents an engulfment hazard.
5. All sweep augers (including portable sweep augers) must be provided with guards that protect against contact with moving parts at both the top and back areas. The only unguarded portion of the sweep auger should be the front point of operation.
6. An observer, in accordance with §1910.272(g), must always be positioned outside the storage bin monitoring the activities of workers inside the bin.
7. If a worker enters the bin while the sweep auger is energized, the employer must utilize engineering controls within the grain bin to prevent the worker from coming into contact with the energized sweep auger. Acceptable engineering controls may include:
 - a. A sweep auger equipped with an attached guard that prevents the worker's contact with the unguarded portion of the auger, in accordance with 29 CFR 1910 Subpart O, Machinery and Machine Guarding.
 - b. A sweep auger equipped with a control mechanism, such as a dead-man switch or other similar device, which will allow for the sweep auger's operation only when the operator is in contact with the device.
 - c. Any workers other than the operator of the sweep auger present in the storage bin while the sweep auger is energized must also be protected in a manner that keeps them out of the zone of danger. For example, this may include the installation of guardrails or catwalks that prevent workers from entering the area within the path of the auger.
8. The auger is provided with a positive speed control mechanism or bin stop device that prevents its uncontrolled rotation around the bin.
9. Workers may not use their hands, legs, or other similar means to dislodge or otherwise directly manipulate the sweep auger while it is energized.
10. If maintenance/adjustments are necessary to the sweep auger, the auger must be unplugged, with the person making the adjustments maintaining the control of the plug, or locked-out in accordance with lockout/tagout procedures.

EXHIBIT B

Table O-10

Distance between Protective Covering and Moving Parts of Equipment	Maximum vertical opening (Horizontal openings are unlimited)
½ to 1 ½ inches	¼ inches
1 ½ to 2 ½ inches	3/8 inches
2 ½ to 3 ½ inches	½ inches
3 ½ to 5 ½ inches	5/8 inches
5 ½ to 6 ½ inches	¾ inches
6 ½ to 7 ½ inches	7/8 inches
7 ½ to 12 ½ inches	1 ¼ inches
12 ½ to 15 ½ inches	1 ½ inches
15 ½ to 17 ½ inches	1 7/8 inches
17 ½ to 31 ½ inches	2 1/8 inches
31 ½ inches to less than 7 feet	6 inches
More than 7 feet	Protective Covering not required